

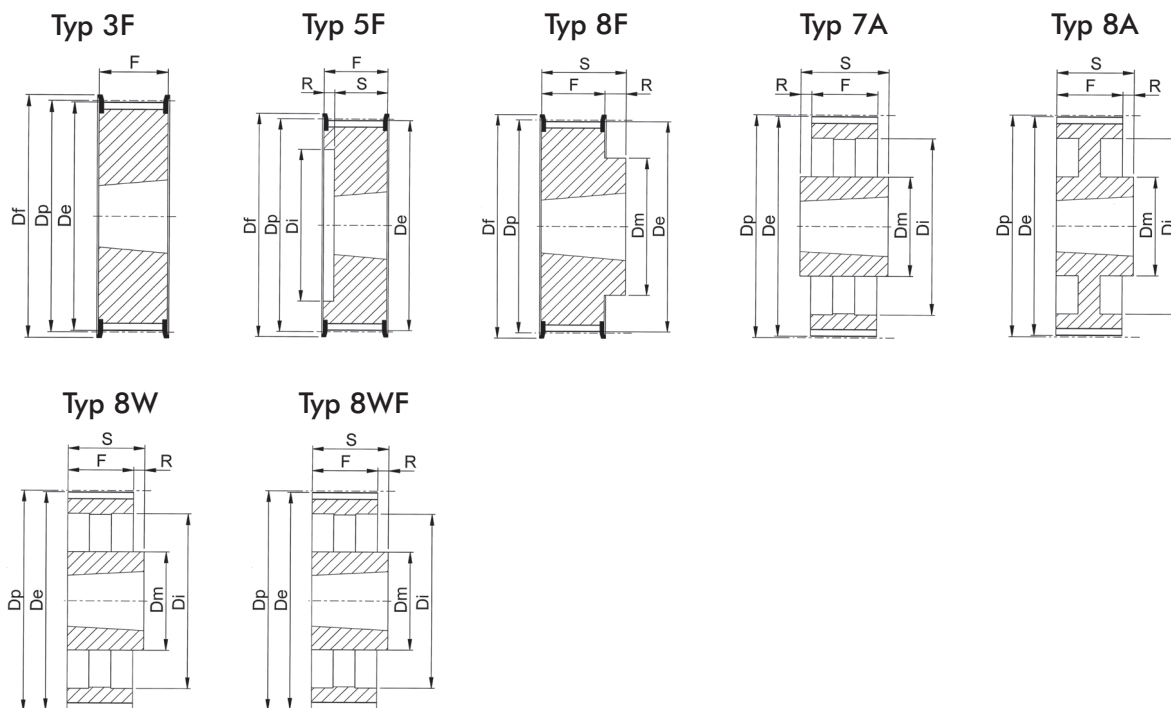

Zahnriemenscheiben

HTD® Zahnriemenscheiben für konische Spannbuchse



HTD® 5M-15

Merkmale	Artikel-Nr.	Typ	Bordscheiben	Buchse	d (max)	Dp	De	Df	Dm	Di	F	S	R	
														[mm]
Stahl	Mit Flansch	T-HTD 34-5M-15	3F	F21	1008	25	54,11	52,97	57	-	22	22	-	-
		T-HTD 36-5M-15	3F	F22	1108	25	57,30	56,15	60	-	22	22	-	-
		T-HTD 38-5M-15	3F	F25	1108	25	60,48	59,34	66	-	22	22	-	-
		T-HTD 40-5M-15	3F	F26	1108	25	63,66	62,52	70	-	22	22	-	-
		T-HTD 44-5M-15	3F	F27	1108	25	70,03	68,89	75	-	22	22	-	-
		T-HTD 48-5M-15	8F	F29	1210	32	76,39	75,25	83	59	22	25	3	-
		T-HTD 56-5M-15	8F	F32	1210	32	89,13	87,39	93	70	22	25	3	-
	T-HTD 64-5M-15	8F	F35	1210	32	101,86	100,72	106	80	22	25	3	-	
	Ohne Flansch	T-HTD 72-5M-15	8A	-	1610	42	114,59	113,45	-	92	22	25	3	-
		T-HTD 80-5M-15	8A	-	1610	42	127,32	126,18	-	92	22	25	3	-
		T-HTD 90-5M-15	8A	-	1610	42	143,24	142,10	-	92	22	25	3	-
		T-HTD 112-5M-15	8A	-	2012	50	178,25	177,11	-	110	20	32	12	-
		T-HTD 136-5M-15	7A	-	2012	50	216,45	215,31	-	110	199	20	32	6

HTD® 8M-20

Merkmale	Artikel-Nr.	Typ	Bordscheiben	Buchse	d (max)	Dp	De	Df	Dm	Di	F	S	R	
														[mm]
Stahl	Mit Flansch	T-HTD 22-8M-20	5F	F22	1108	25	56,02	54,65	60	-	37	28	22	6
		T-HTD 24-8M-20	5F	F25	1108	25	61,12	59,75	66	-	44	28	22	6
		T-HTD 26-8M-20	5F	F26	1108	25	66,21	64,84	70	-	45	28	22	6
		T-HTD 28-8M-20	5F	F27	1108	25	71,30	70,08	75	-	50	28	22	6
		T-HTD 30-8M-20	5F	F29	1108	25	76,39	75,13	83	-	58	28	22	6
		T-HTD 32-8M-20	5F	F30	1610	42	81,49	80,16	87	-	63	28	25	3
		T-HTD 34-8M-20	5F	F31	1610	42	86,58	85,22	91	-	64	28	25	3
		T-HTD 36-8M-20	5F	F33	1610	42	91,67	90,30	97	-	68	28	25	3
		T-HTD 38-8M-20	5F	F34	1610	42	96,77	95,39	102	-	72	28	25	3
		T-HTD 40-8M-20	5F	F35	1610	42	101,86	100,49	106	-	76	28	25	3
		T-HTD 44-8M-20	8F	F38	2012	50	112,05	110,67	120	93	-	28	32	4
		T-HTD 48-8M-20	8F	F40	2012	50	122,23	120,86	128	96	-	28	32	4
		T-HTD 56-8M-20	8F	F48	2012	50	142,60	141,23	150	110	-	28	32	4
		T-HTD 64-8M-20	8WF	F52	2012	50	162,97	161,60	168	110	137	28	32	4
		T-HTD 72-8M-20	8WF	F57	2012	50	183,35	181,97	192	110	158	28	32	4
		Grauguss	Ohne Flansch	T-HTD 80-8M-20	8W	-	2012	50	203,72	202,35	-	110	180	28
T-HTD 90-8M-20	8A			-	2012	50	229,18	227,81	-	110	204	28	32	4
T-HTD 114-8M-20	8A			-	2517	60	366,69	365,32	-	125	336	28	32	4

Zahnriemenscheiben

HTD® Zahnriemenscheiben für konische Spannbuchse

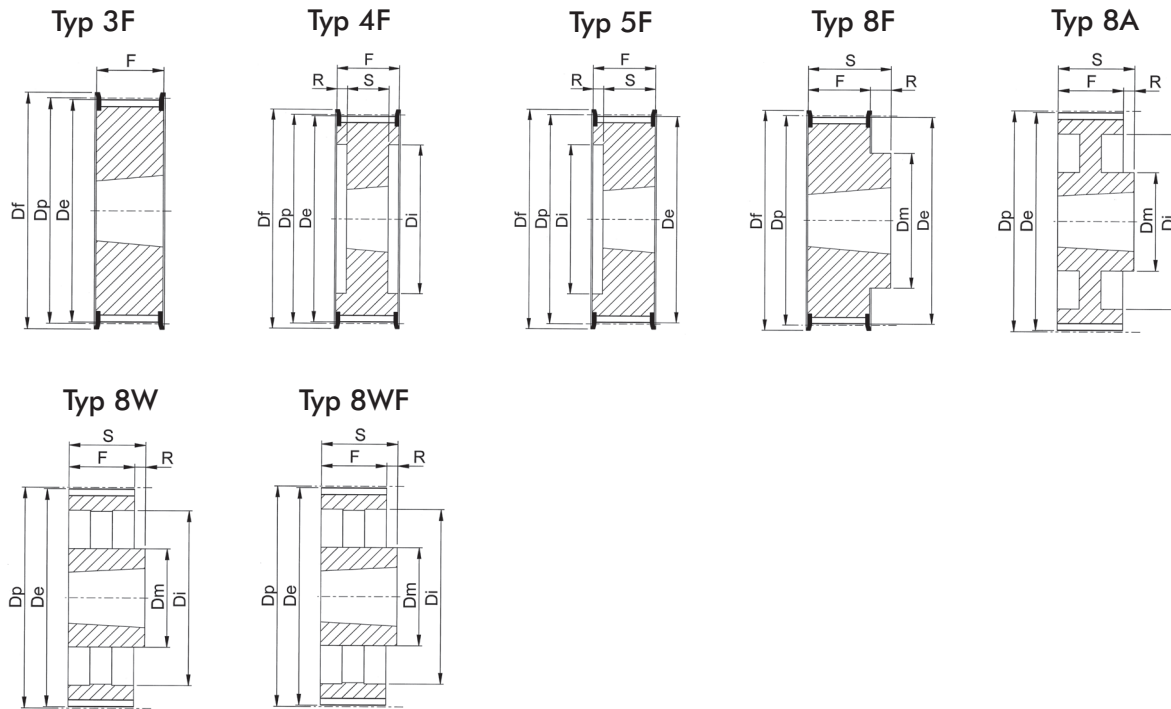

HTD® 8M-30

Merkmale	Artikel-Nr.	Typ	Bordscheiben	Buchse	d (max)	Dp	De	Df	Dm	Di	F	S	R	
														[mm]
Stahl	Mit Flansch	T-HTD 22-8M-30	5F	F22	1108	25	56,02	54,65	60	-	37	38	22	16
		T-HTD 24-8M-30	5F	F25	1108	25	61,12	59,75	66	-	44	38	22	16
		T-HTD 26-8M-30	5F	F26	1108	25	66,21	64,84	70	-	44	38	22	16
		T-HTD 28-8M-30	5F	F27	1210	32	71,30	70,08	75	-	50	38	25	13
		T-HTD 30-8M-30	3F	F29	1615	42	76,39	75,13	83	-	-	38	38	-
		T-HTD 32-8M-30	3F	F30	1615	42	81,49	80,16	87	-	-	38	38	-
		T-HTD 34-8M-30	3F	F31	1615	42	86,58	85,22	91	-	-	38	38	-
		T-HTD 36-8M-30	3F	F33	1615	42	91,67	90,30	97	-	-	38	38	-
		T-HTD 38-8M-30	3F	F34	1615	42	96,77	95,39	102	-	-	38	38	-
		T-HTD 40-8M-30	3F	F35	1615	42	101,86	100,49	106	-	-	38	38	-
		T-HTD 44-8M-30	4F	F38	2012	50	112,05	110,67	120	-	86	38	32	6
		T-HTD 48-8M-30	4F	F40	2012	50	122,23	120,86	128	-	90	38	32	6
		T-HTD 56-8M-30	4F	F48	2012	50	142,60	141,23	150	-	110	38	32	6
		T-HTD 64-8M-30	8F	F52	2517	60	162,97	161,60	168	125	-	38	45	7
T-HTD 72-8M-30	8WF	F57	2517	60	183,35	181,97	192	125	158	38	45	7		
Grauguss	Ohne Flansch	T-HTD 80-8M-30	8W		2517	60	203,72	202,35	-	125	180	38	45	7
		T-HTD 90-8M-30	8A		2517	60	229,18	227,81	-	125	204	38	45	7
		T-HTD 112-8M-30	8A		2517	60	285,21	283,83	-	125	254	38	45	7
		T-HTD 144-8M-30	8A		2517	60	366,69	365,32	-	125	336	38	45	7





Zahnriemenscheiben

HTD® Zahnriemenscheiben für konische Spannbuchse

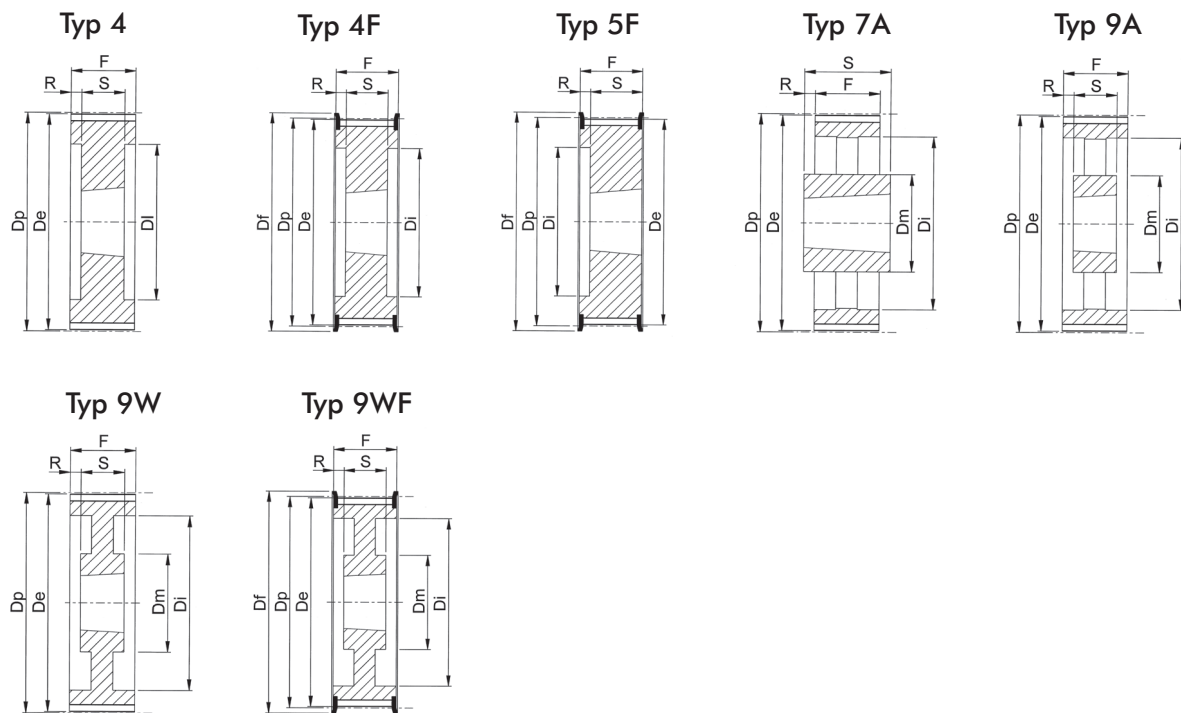

HTD® 8M-50

Merkmale	Artikel-Nr.	Typ	Bordscheiben	Buchse	d (max)	Dp	De	Df	Dm	Di	F	S	R	
														[mm]
Stahl	Mit Flansch	T-HTD 28-8M-50	4F	F27	1210	32	71,30	70,08	75	-	50	60	25	17,5
		T-HTD 30-8M-50	5F	F29	1615	42	76,39	75,13	83	-	58	60	38	22,0
		T-HTD 32-8M-50	5F	F30	1615	42	81,49	80,16	87	-	62	60	38	22,0
		T-HTD 34-8M-50	5F	F31	1615	42	86,58	85,22	91	-	65	60	38	22,0
		T-HTD 36-8M-50	5F	F33	1615	42	91,67	90,30	97	-	68	60	38	22,0
		T-HTD 38-8M-50	5F	F34	1615	42	96,77	95,39	102	-	72	60	38	22,0
		T-HTD 40-8M-50	4F	F35	2012	50	101,86	100,49	106	-	82	60	32	14,0
		T-HTD 44-8M-50	4F	F38	2012	50	112,05	110,67	120	-	91	60	32	14,0
		T-HTD 48-8M-50	4F	F40	2012	50	122,23	120,86	128	-	95	60	32	14,0
		T-HTD 56-8M-50	4F	F48	2517	60	142,60	141,23	150	-	116	60	45	7,5
		T-HTD 64-8M-50	4F	F52	2517	60	162,97	161,60	168	-	137	60	45	7,5
		T-HTD 72-8M-50	9WF	F57	2517	60	183,35	181,97	192	125	158	60	45	7,5
Grauguss	Ohne Flansch	T-HTD 80-8M-50	4		3020	75	203,72	202,35	-	-	180	60	51	4,5
		T-HTD 90-8M-50	9W		3020	75	229,18	227,81	-	170	204	60	51	4,5
		T-HTD 112-8M-50	9W		3020	75	285,21	283,83	-	170	260	60	51	4,5
		T-HTD 144-8M-50	9A		3020	75	366,69	365,32	-	170	341	60	51	4,5
		T-HTD 168-8M-50	7A		3525	90	427,81	426,44	-	198	402	60	65	2,5
		T-HTD 192-8M-50	7A		3525	90	488,92	487,55	-	198	460	60	65	2,5

HTD® 8M-85

Merkmale	Artikel-Nr.	Typ	Bordscheiben	Buchse	d (max)	Dp	De	Df	Dm	Di	F	S	R	
														[mm]
Stahl	Mit Flansch	T-HTD 34-8M-85	4F	F31	1615	42	86,58	85,22	91	-	65	95	38	28,5
		T-HTD 36-8M-85	4F	F33	1615	42	91,67	90,30	97	-	68	95	38	28,5
		T-HTD 38-8M-85	4F	F34	1615	42	96,77	95,39	102	-	72	95	38	28,5
		T-HTD 40-8M-85	4F	F35	2012	50	101,86	100,49	106	-	82	95	32	31,5
		T-HTD 44-8M-85	4F	F38	2012	50	112,05	110,67	120	-	91	95	32	31,5
		T-HTD 48-8M-85	4F	F40	2517	60	122,23	120,86	128	-	100	95	45	25,0
		T-HTD 56-8M-85	4F	F48	2517	60	142,60	141,23	150	-	117	95	45	25,0
		T-HTD 64-8M-85	4F	F52	2517	60	162,97	161,60	168	-	137	95	45	25,0
		T-HTD 72-8M-85	4F	F57	3020	75	183,35	181,97	192	-	158	95	51	22,0
Grauguss	Ohne Flansch	T-HTD 80-8M-85	4		3020	75	203,72	202,35	-	-	180	95	51	22,0
		T-HTD 90-8M-85	9W		3020	75	229,18	227,81	-	170	204	95	51	22,0
		T-HTD 112-8M-85	9W		3020	75	285,21	283,83	-	170	260	95	51	22,0
		T-HTD 144-8M-85	9A		3525	90	366,69	365,32	-	198	336	95	65	15,0
		T-HTD 168-8M-85	9A		3525	90	427,81	426,44	-	198	395	95	65	15,0
		T-HTD 192-8M-85	9A		3525	90	488,92	487,55	-	198	455	95	65	15,0

HTD® Zahnriemenscheiben für konische Spannbuchse

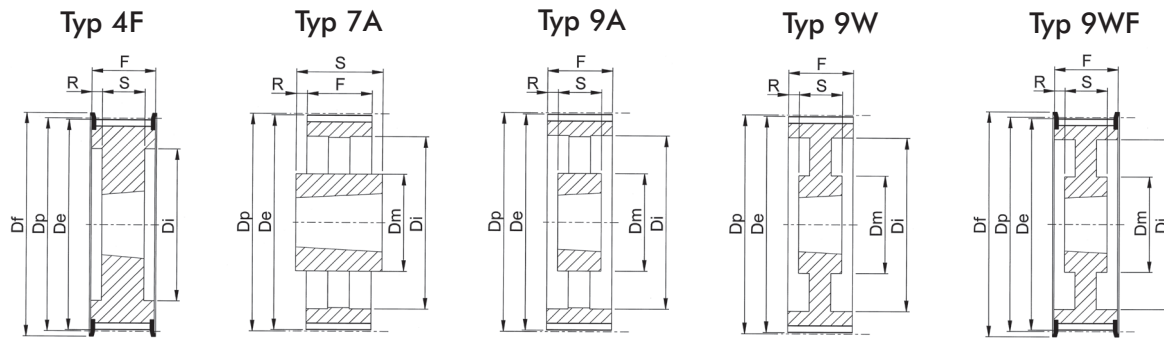

HTD® 14M-40

Merkmale	Artikel-Nr.	Typ	Bordscheiben	Buchse	d (max)	Dp	De	Df	Dm	Di	F	S	R	
														[mm]
Stahl	Mit Flansch	T-HTD 28-14M-40	4F	F40	2012	50	124,78	122,12	128	-	94	54	32	11,0
		T-HTD 29-14M-40	4F	F43	2012	50	129,23	126,57	138	-	98	54	32	11,0
		T-HTD 30-14M-40	4F	F43	2012	50	133,69	130,99	138	-	98	54	32	11,0
		T-HTD 32-14M-40	4F	F49	2012	50	142,60	139,88	154	-	108	54	32	11,0
		T-HTD 34-14M-40	4F	F51	2517	60	151,52	148,79	160	-	110	54	45	4,5
		T-HTD 36-14M-40	4F	F52	2517	60	160,43	157,68	168	-	120	54	45	4,5
		T-HTD 38-14M-40	4F	F81	2517	60	169,34	166,60	184	-	130	54	45	4,5
		T-HTD 40-14M-40	4F	F56	2517	60	178,25	175,49	188	-	138	54	45	4,5
		T-HTD 44-14M-40	4F	F61	3020	75	196,08	193,28	212	-	155	54	51	1,5
		T-HTD 48-14M-40	4F	F62	3020	75	213,90	211,11	226	-	170	54	51	1,5
	T-HTD 56-14M-40	9WF	F66	3020	75	249,55	246,76	256	170	208	54	51	1,5	
Grauguss	Ohne Flansch	T-HTD 64-14M-40	9WF	F70	3020	75	285,21	282,41	296	170	240	54	51	1,5
		T-HTD 72-14M-40	9W		3020	75	320,86	318,06	-	170	280	54	51	1,5
		T-HTD 80-14M-40	9A		3020	75	356,51	353,71	-	170	315	54	51	1,5
		T-HTD 90-14M-40	9A		3020	75	401,07	398,28	-	170	360	54	51	1,5
		T-HTD 112-14M-40	9A		3020	75	499,11	496,32	-	170	457	54	51	1,5
		T-HTD 144-14M-40	9A		3020	75	641,71	638,92	-	170	600	54	51	1,5
		T-HTD 168-14M-40	9A		3020	75	748,66	745,87	-	170	706	54	51	1,5
		T-HTD 192-14M-40	9A		3020	75	855,62	852,82	-	170	813	54	51	1,5
		T-HTD 216-14M-40	9A		3020	75	962,57	959,76	-	170	920	54	51	1,5



HTD® 14M-55

Merkmale	Artikel-Nr.	Typ	Bordscheiben	Buchse	d (max)	Dp	De	Df	Dm	Di	F	S	R	
														[mm]
Stahl	Mit Flansch	T-HTD 28-14M-55	4F	F40	2012	50	124,78	122,12	128	-	94	70	32	19,0
		T-HTD 29-14M-55	4F	F43	2012	50	129,23	126,57	138	-	100	70	32	19,0
		T-HTD 30-14M-55	4F	F43	2517	60	133,69	130,99	138	-	100	70	45	12,5
		T-HTD 32-14M-55	4F	F49	2517	60	142,60	139,88	154	-	108	70	45	12,5
		T-HTD 34-14M-55	4F	F51	2517	60	151,52	148,79	160	-	110	70	45	12,5
		T-HTD 36-14M-55	4F	F52	2517	60	160,43	157,68	168	-	120	70	45	12,5
		T-HTD 38-14M-55	4F	F81	2517	60	169,34	166,60	184	-	130	70	45	12,5
		T-HTD 40-14M-55	4F	F56	2517	60	178,25	175,49	188	-	138	70	45	12,5
		T-HTD 44-14M-55	4F	F61	3020	75	196,08	193,28	212	-	155	70	51	9,5
		T-HTD 48-14M-55	4F	F62	3020	75	213,90	211,11	226	-	170	70	51	9,5
	T-HTD 56-14M-55	9WF	F66	3020	75	249,55	246,76	256	170	208	70	51	9,5	
Grauguss	Ohne Flansch	T-HTD 64-14M-55	9WF	F70	3020	75	285,21	282,41	296	170	240	70	51	9,5
		T-HTD 72-14M-55	9W		3020	75	320,86	318,06	-	170	280	70	51	9,5
		T-HTD 80-14M-55	9A		3020	75	356,51	353,71	-	170	315	70	51	9,5
		T-HTD 90-14M-55	9A		3020	75	401,07	398,28	-	170	360	70	51	9,5
		T-HTD 112-14M-55	9A		3020	75	499,11	496,32	-	170	457	70	51	9,5
		T-HTD 144-14M-55	9A		3020	75	641,71	638,92	-	170	600	70	51	9,5
		T-HTD 168-14M-55	9A		3020	75	748,66	745,87	-	170	706	70	51	9,5
		T-HTD 192-14M-55	9A		3020	75	855,62	852,82	-	170	813	70	51	9,5
		T-HTD 216-14M-55	7A		3535	90	962,57	959,76	-	190	920	70	89	9,5



Zahnriemenscheiben

HTD® Zahnriemenscheiben für konische Spannbuchse

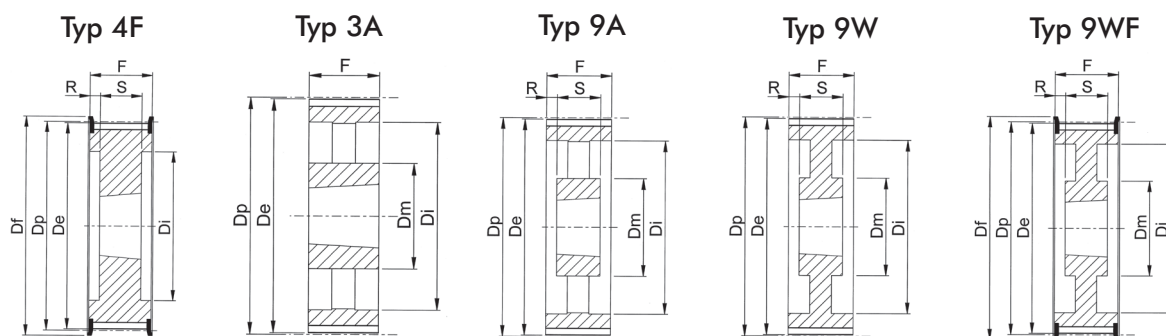

HTD® 14M-85

Merkmale	Artikel-Nr.	Typ	Bordscheiben	Buchse	d (max)	Dp	De	Df	Dm	Di	F	S	R	
														[mm]
Stahl	Mit Flansch	T-HTD 28-14M-85	4F	F40	2517	60	124,78	122,12	128	-	98	102	45	28,5
		T-HTD 29-14M-85	4F	F43	2517	60	129,23	126,57	138	-	100	102	45	28,5
		T-HTD 30-14M-85	4F	F43	2517	60	133,69	130,99	138	-	100	102	45	28,5
		T-HTD 32-14M-85	4F	F49	2517	60	142,60	139,88	154	-	108	102	45	28,5
		T-HTD 34-14M-85	4F	F51	2517	60	151,52	148,79	160	-	110	102	45	28,5
		T-HTD 36-14M-85	4F	F52	3020	75	160,43	157,68	168	-	120	102	51	25,5
		T-HTD 38-14M-85	4F	F81	3020	75	169,34	166,60	184	-	130	102	51	25,5
		T-HTD 40-14M-85	4F	F56	3020	75	178,25	175,49	188	-	138	102	51	25,5
		T-HTD 44-14M-85	4F	F61	3020	75	196,08	193,28	212	-	153	102	51	25,5
		T-HTD 48-14M-85	4F	F62	3020	75	213,90	211,11	226	-	170	102	51	25,5
T-HTD 56-14M-85	4F	F66	3525	90	249,55	246,76	256	-	210	102	65	18,5		
Grauguss	Ohne Flansch	T-HTD 64-14M-85	9WF	F70	3525	90	285,21	282,41	296	190	240	102	65	18,5
		T-HTD 72-14M-85	9W		3525	90	320,86	318,06	-	190	280	102	65	18,5
		T-HTD 80-14M-85	9A		3525	90	356,51	353,71	-	190	315	102	65	18,5
		T-HTD 90-14M-85	9A		3525	90	401,07	398,28	-	190	360	102	65	18,5
		T-HTD 112-14M-85	9A		3525	90	499,11	496,32	-	190	457	102	65	18,5
		T-HTD 144-14M-85	9A		3525	90	641,71	638,92	-	190	600	102	65	18,5
		T-HTD 168-14M-85	9A		3525	90	748,66	745,87	-	190	706	102	65	18,5
		T-HTD 192-14M-85	3A		4040	100	855,62	852,82	-	190	813	102	102	-
		T-HTD 216-14M-85	3A		4040	100	962,57	959,76	-	190	920	102	102	-

HTD® 14M-115

Merkmale	Artikel-Nr.	Typ	Bordscheiben	Buchse	d (max)	Dp	De	Df	Dm	Di	F	S	R	
														[mm]
Stahl	Mit Flansch	T-HTD 28-14M-115	4F	F40	2517	60	124,78	122,12	128	-	98	133	45	44,0
		T-HTD 29-14M-115	4F	F43	2517	60	129,23	126,57	138	-	100	133	45	44,0
		T-HTD 30-14M-115	4F	F43	2517	60	133,69	130,99	138	-	100	133	45	44,0
		T-HTD 32-14M-115	4F	F49	2517	60	142,60	139,88	154	-	108	133	45	44,0
		T-HTD 34-14M-115	4F	F51	2517	60	151,52	148,79	160	-	110	133	45	44,0
		T-HTD 36-14M-115	4F	F52	3020	75	160,43	157,68	168	-	125	133	51	41,0
		T-HTD 38-14M-115	4F	F81	3020	75	169,34	166,60	184	-	130	133	51	41,0
		T-HTD 40-14M-115	4F	F56	3020	75	178,25	175,49	188	-	138	133	51	41,0
		T-HTD 44-14M-115	4F	F61	3030	75	196,08	193,28	212	-	155	133	76	28,5
		T-HTD 48-14M-115	4F	F62	3030	75	213,90	211,11	226	-	170	133	76	28,5
T-HTD 56-14M-115	4F	F66	3535	90	249,55	246,76	256	-	208	133	89	22,0		
Grauguss	Ohne Flansch	T-HTD 64-14M-115	9WF	F70	3535	90	285,21	282,41	296	190	240	133	89	22,0
		T-HTD 72-14M-115	9W		3535	90	320,86	318,06	-	190	280	133	89	22,0
		T-HTD 80-14M-115	9A		3535	90	356,51	353,71	-	190	315	133	89	22,0
		T-HTD 90-14M-115	9A		3535	90	401,07	398,28	-	190	360	133	89	22,0
		T-HTD 112-14M-115	9A		3535	90	499,11	496,32	-	190	457	133	89	22,0
		T-HTD 144-14M-115	9A		4040	100	641,71	638,92	-	230	600	133	102	15,5
		T-HTD 168-14M-115	9A		4040	100	748,66	745,87	-	230	706	133	102	15,5
		T-HTD 192-14M-115	9A		4040	100	855,62	852,82	-	230	813	133	102	15,5
		T-HTD 216-14M-115	9A		4040	100	962,57	959,76	-	230	920	133	102	15,5

HTD® Zahnriemenscheiben für konische Spannbuchse

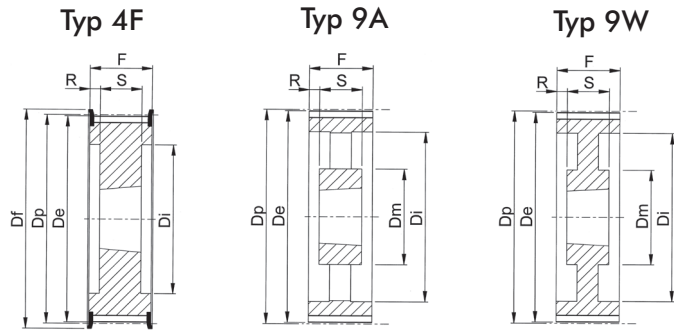

HTD® 14M-170

Merkmale	Artikel-Nr.	Typ	Bordscheiben	Buchse	d (max)	Dp	De	Df	Dm	Di	F	S	R	
														[mm]
Stahl	Mit Flansch	T-HTD 38-14M-170	4F	F81	3030	75	169,34	166,60	184	-	130	187	76	55,5
		T-HTD 40-14M-170	4F	F56	3030	75	178,25	175,49	188	-	138	187	76	55,5
		T-HTD 44-14M-170	4F	F61	3535	90	196,08	193,28	212	-	153	187	89	49,0
		T-HTD 48-14M-170	4F	F62	3535	90	213,90	211,11	226	-	170	187	89	49,0
		T-HTD 56-14M-170	4F	F66	3535	90	249,55	246,76	256	-	208	187	89	49,0
		T-HTD 64-14M-170	4F	F70	4040	100	285,21	282,41	296	-	240	187	102	42,5
Grauguss	Ohne Flansch	T-HTD 72-14M-170	9W		4040	100	320,86	318,06	-	230	280	187	102	42,5
		T-HTD 80-14M-170	9W		4040	100	356,51	353,71	-	230	315	187	102	42,5
		T-HTD 90-14M-170	9A		4040	100	401,07	398,28	-	230	360	187	102	42,5
		T-HTD 112-14M-170	9A		5050	125	499,11	496,32	-	265	457	187	127	30,0
		T-HTD 144-14M-170	9A		5050	125	641,71	638,92	-	265	600	187	127	30,0
		T-HTD 168-14M-170	9A		5050	125	748,66	745,87	-	265	706	187	127	30,0
		T-HTD 192-14M-170	9A		5050	125	855,62	852,82	-	265	813	187	127	30,0
		T-HTD 216-14M-170	9A		5050	125	962,57	959,76	-	265	920	187	127	30,0

